

Inverter User Manual



Table Of Contents

1. Information on this Manual	01
1.1 Validity	01
1.2 Scope	01
1.3 Target Group	01
1.4 Label Description	01
1.5 Safety Instructions	02
2. Introduction	03
3. Installation	04
3.1 Unpacking and Inspection	04
3.1.1 Open-box Inspection	04
3.1.2 Installation Tools	04
3.2 Mounting Unit	05
3.3 External Protective Grounding Connection	07
3.4 AC Input / Output Connection	08
3.5 PV Connection	11
3.6 Battery Connection	13
3.6.1 Lead-acid Battery Connection	13
3.6.2 Lithium Battery Connection (Optional)	15
3.7 Final Assembly	16
3.8 Smart Communication Stick Connection(Optional)	16
4. Operation	16
4.1 Power ON/OFF	16
4.2 Operation and Display Panel	16
4.2.1 LCD Display Icons	18
4.2.2 LCD Setting	20
4.3 Display Information	29
5. Fault Reference Code	33
6. Alarm Reference Code	36
7. Battery Equalization	38
8. Trouble Shooting	40

1. Information on this Manual

1.1 Validity

This manual is valid for the following devices:

- Solar inverter

1.2 Scope

This manual describes the assembly, installation, operation and troubleshooting of this unit.

Please read this manual carefully before installations and operations.

1.3 Target Group





This document is intended for qualified persons and end users. Tasks that do not require any particular qualification can also be performed by end users. Qualified persons must have the following skills:

- Knowledge of how an inverter works and is operated
- Training in how to deal with the dangers and risks associated with installing and using electrical devices and installations
- Training in the installation and commissioning of electrical devices and installations
- Knowledge of the applicable standards and directives
- Knowledge of the compliance with this document and all safety information



1.4 Label Description

In order to ensure the user's personal safety when using this product, the inverter and manual provides relevant identification information and uses appropriate symbols to alert the user, who should carefully read the following list of symbols used in this manual.

Labels on Inverter

	CAUTION Do not disconnect under load!
	Danger: High Voltage! Danger: Electrical Hazard!
	Start maintaining the INVERTER at least 5 minutes after the INVERTER disconnected from all external power supplies.
	Read instructions carefully before performing any operation on the INVERTER.
	Grounding: The system must be firmly grounded for operator safety.

Labels in the documentation

 WARNING!	A high level of potential danger, which, if not avoided, could result in death or serious injury to personnel.
 CAUTION!	A moderate or low level of potential danger, which, if not avoided, could result in moderate or minor injuries to personnel. In some bad situation, it could result in death or serious injury to personnel.

1.5 Safety Instructions



WARNING!

**This chapter contains important safety and operating instructions.
Read and keep this manual for future reference.**

01. Please be clear which kind of battery system you want, lithium battery system or lead-acid battery system, if you choose the wrong system, energy storage system can't work normally.
02. Before using the unit, read all instructions and cautionary marking on the unit, the batteries and all appropriate sections of this manual. The company has the right not to quality assurance, if not according to the instructions of this manual for installation and cause equipment damage.
03. All the operation and connection please professional electrical or mechanical engineer.
04. All the electrical installation must comply with the local electrical safety standards.
05. When install PV modules in the daytime, installer should cover the PV modules by opaque materials, otherwise it will be dangerous as high terminal voltage of modules in the sunshine.
06. CAUTION - To reduce risk of injury, charge only deep-cycle lead-acid type rechargeable batteries and lithium batteries. Other types of batteries may burst, causing personal injury and damage.
07. Do not disassemble the unit. Take it to a qualified service center when service or repair is required. Incorrect re-assembly may result in a risk of electric shock or fire.
08. To reduce risk of electric shock, disconnect all wirings before attempting any maintenance or cleaning. Turning off the unit will not reduce this risk.
09. NEVER charge a frozen battery.
10. For optimum operation of this inverter, please follow required spec to select appropriate cable size. It's very important to correctly operate this inverter.

11. Be very cautious when working with metal tools on or around batteries. A potential risk exists to drop a tool to spark or short circuit batteries or other electrical parts and could cause an explosion.
12. Please strictly follow installation procedure when you want to disconnect AC or DC terminals. Please refer to INSTALLATION section of this manual for the details.
13. GROUNDING INSTRUCTIONS -This inverter should be connected to a permanent grounded wiring system. Be sure to comply with local requirements and regulation to install this inverter.
14. NEVER cause AC output and DC input short circuited. Do NOT connect to the mains when DC input short circuits.
15. Make sure the inverter is completely assembled, before the operation.

2. Introduction

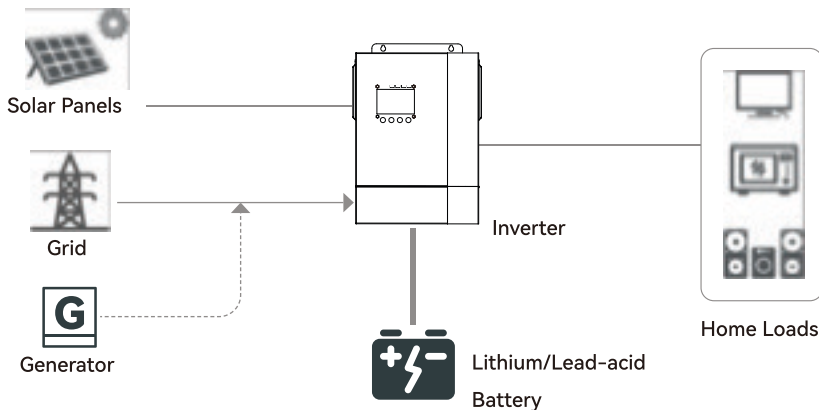

Solar Energy Storage System

This is a multifunctional solar inverter, integrated with a MPPT solar charge controller, a high frequency pure sine wave inverter and a UPS function module in one machine, which is perfect for off grid backup power and self-consumption applications.

The whole system also need other devices to achieve complete running such as PV modules, generator, or utility grid. Please consult with your system integrator for other possible system architectures depending on your requirements.

3. Installation

3.1 Unpacking and Inspection

3.1.1 Open-box Inspection

Products have been strictly tested before leaving the factory. Please sign for them after inspection. If the product is damaged, please contact the local distributor. Please open the box to check whether the outer packaging is intact or damaged, whether the internal equipment is damaged.

3.1.2 Installation Tools

Installation Tools	Multi-meter 	Protective gloves 	Insulated anti-smashing shoes 
	Safety glasses 	ESD wrist strap 	Hammer drill 
	Electric screwdriver 	Cross screwdriver 	Rubber mallet 
	Spirit level 	Wire cutter / stripper 	Terminal crimping tool 

3.2 Mounting Unit

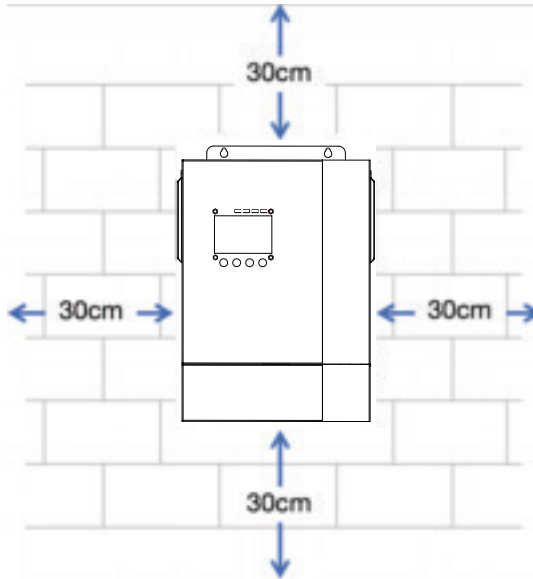

Consider the following points before selecting where to install:

- Do not mount the inverter on flammable construction materials.
- Mount on a solid surface.
- Install this inverter at eye level in order to allow the LCD display to be read at all times.
- The ambient temperature should be between -10°C and 60°C to ensure optimal operation.
- The recommended installation position is to be adhered to the wall vertically.
- Be sure to keep other objects and surfaces as shown in the diagram above to guarantee sufficient heat dissipation and to have enough space for removing wires.



WARNING!

Inverter is suitable for mounting on concrete or other non-combustible surface only.



WARNING!

Stay away from strong magnetic fields and avoid electromagnetic interference.

If there is a wireless radio or wireless communication device below 30MHz near the installation location, the distance between the inverter and the wireless electromagnetic interference device must exceed 30m.

Follow the installation steps:

1. Use $\phi 8$ drilling bit drill holes on the mounting surface. The distance between 2 holes is 120mm. Then insert the expansion screw(M6). M6 expansion screw is suggested.



2. Pick up the inverter vertically and align the screw at the top of the inverter with the screw already installed on the wall. Hang the inverter on the mounting surface by the screws.

Before connecting all wiring, please take off bottom cover by removing two screws as shown below:

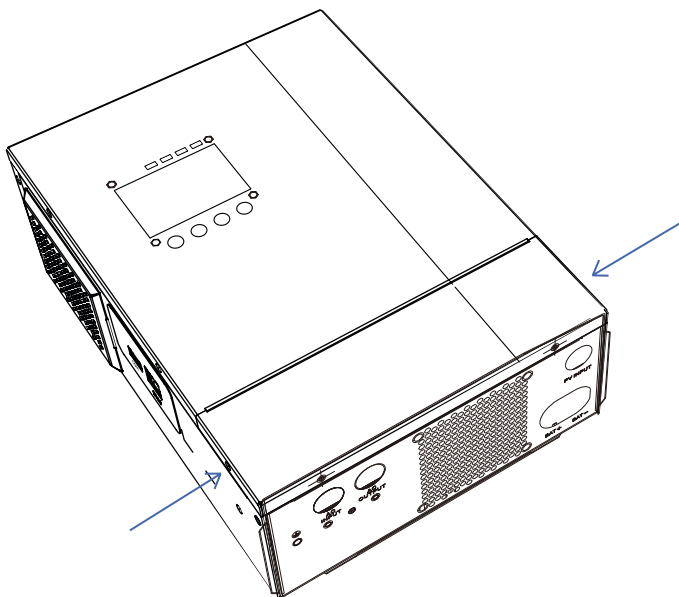

3.3 External Protective Grounding Connection



DANGER

Ensure a reliable connection of the grounding wire to prevent electrical shock hazards.



WARNING

- The external grounding protection point provides a reliable grounding. Do not use inappropriate grounding conductors as it may result in product damage or personal injury.
- If unsure about the grounding connection, please consult a professional for proper guidance.

The external grounding cable and OT terminal(Corresponding to M4 screws) are to be prepared by customer. The grounding cable must be yellow-green color.

1. Remove insulation sleeve a proper length from the head of cables.



2. Use OT terminal crimping tool make cable and terminal crimped tightly.



3. Connect the ground cable with M4 screw.

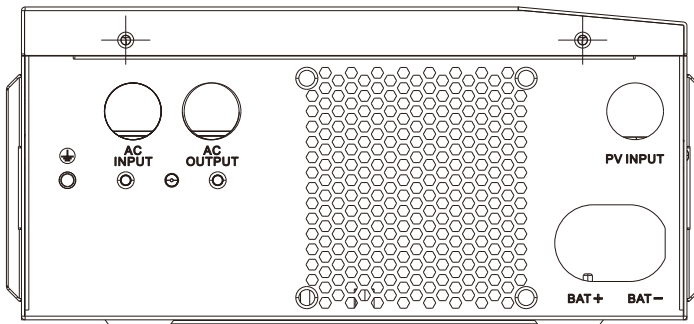

3.4 AC Input / Output Connection



CAUTION!

Before connecting to AC input power source, please install a separate AC breaker between inverter and AC input power source. This will ensure the inverter can be securely disconnected during maintenance and fully protected from over current of AC input. The recommended spec of AC breaker is 16A.



CAUTION!

There are two terminal blocks with 'AC IN', 'AC OUT' markings. Please do NOT mis-connect input and output connectors.



CAUTION!

Be sure to connect AC cables with correct polarity. If L and N wires are connected reversely, it may cause utility short-circuited when these inverters are worked in parallel operation



WARNING!

All wiring must be performed by a qualified personnel.



WARNING!

It's very important for system safety and efficient operation to use appropriate cable for AC input connection. To reduce risk of injury, please use the proper recommended cable size as below.

Suggestion for AC input wires

Gauge	Cable (mm ²)
16 AWG	1.31



WARNING!

It's very important for system safety and efficient operation to use appropriate cable for AC dual output connection. To reduce risk of injury, please use the proper recommended cable size as below.

Suggestion for AC output wires

Gauge	Cable (mm ²)
16 AWG	1.31



WARNING!

Make sure AC power is disconnected before attempting to connect AC power to the unit.

All operations during the electrical connection process, as well as the specifications of cables and components used, must comply with local laws and regulations. The cable color mentioned below is for typical reference.

Please follow below steps to implement AC input / output connection:

1. Before making AC connection, be sure to open AC circuit breaker first.
2. Remove insulation sleeve 9mm from the head of cables, shorten the conductor part to 7 mm. Insert the cable into the tubular terminal. Then use terminal crimping tool make the terminal and cable connected tightly.

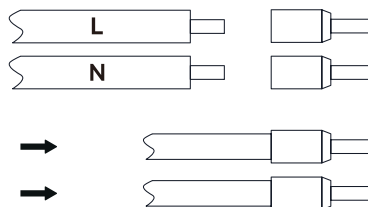

3. Insert AC input/output cables according to polarities indicated on terminal block and tighten the terminal screws.

L → LINE (brown or black)

N → Neutral (blue)

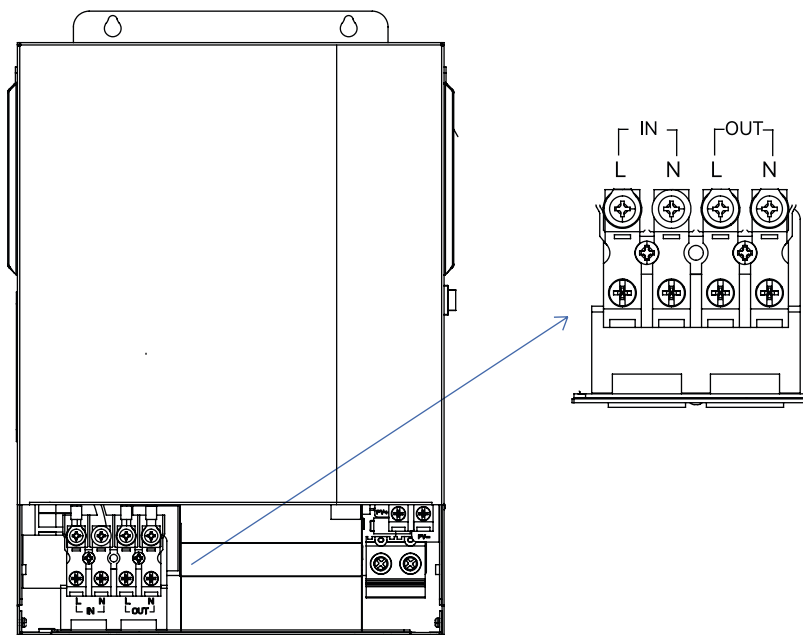

4. Make sure the cables are securely connected.



CAUTION!

Appliances such as air conditioner are required at least 2~3 minutes to restart because it's required to have enough time to balance refrigerant gas inside of circuits. If a power shortage occurs and recovers in a short time, it will cause damage to your connected appliances. To prevent this kind of damage, please check with manufacturer of air conditioner that if it's equipped with time-delay function before installation. Otherwise, this off grid solar inverter will trig overload fault and cut off output to protect your appliance but sometimes it still causes internal damage to the air condition.

3.5 PV Connection



CAUTION!

Before connecting to PV modules, please install a separate DC circuit breaker between inverter and PV modules.

The recommended spec of DC breaker is 16A with a maximum operating voltage greater than 115VDC for inverter.



WARNING!

Do not ground the positive or negative terminals of the PV modules, as this can severely damage the inverter.



WARNING!

Exposure to sunlight can generate lethal high voltages in photovoltaic strings, so strictly adhere to the safety precautions listed in the photovoltaic string and related documents.



WARNING!

Make sure to connect the PV terminals to the corresponding ports on the inverter, as reversing the polarity can damage the inverter.



WARNING!

All wiring must be performed by a qualified personnel.



WARNING!

It's very important for system safety and efficient operation to use appropriate cable for PV module connection. To reduce risk of injury, please use the proper recommended cable size as below. The cable color mentioned below is for typical reference.

Gauge	Cable (mm ²)
14 AWG	2.075

PV Module Selection:

When selecting proper PV modules, please be sure to consider below parameters:

1. Open circuit Voltage (Voc) of PV modules not exceeds max. PV array open circuit voltage of inverter.
2. Open circuit Voltage (Voc) of PV modules should be higher than start-up voltage.

Max. PV Array Open Circuit Voltage	115Vdc
Start-up Voltage	20Vdc
PV Array MPPT Voltage Range	17-115Vdc



WARNING!

Please do not connect any DC switches or AC/DC circuit breakers before completing the electrical connections.

Please follow below steps to implement PV module connection:

1. Before making PV connection, be sure to open DC circuit breaker first.
2. Remove insulation sleeve 9mm from the head of cables, shorten the conductor part to 7 mm. Insert the cable into the tubular terminal. Then use terminal crimping tool make the terminal and cable connected tightly

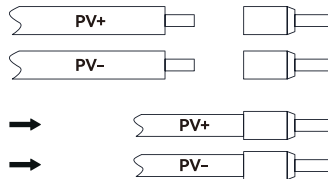

3. Use multi-meter check to ensure the polarities are correct.
 4. Insert PV cables according to polarities indicated on terminal block and tighten the terminal screws.
- + → PV+ (red)
- → PV- (black)

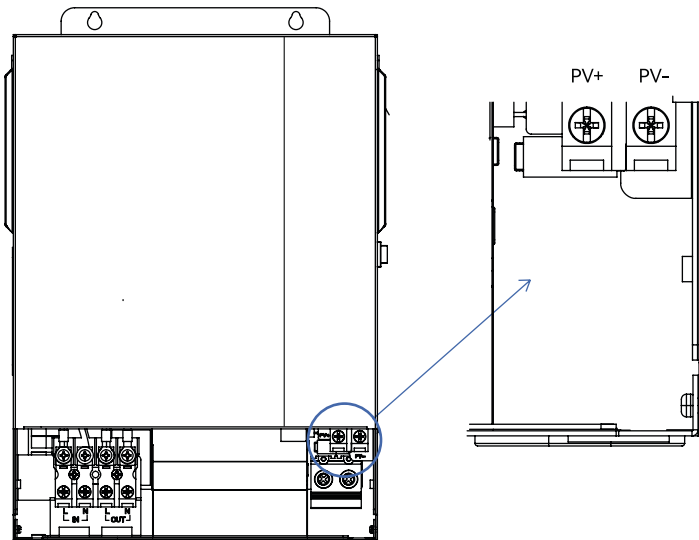

5. Make sure the cables are securely connected.

3.6 Battery Connection

3.6.1 Lead-acid Battery Connection

User can choose proper capacity lead acid battery with a nominal voltage at 12V. Also, you need to choose battery type as 'AGM or FLD(flooded)'



CAUTION!

For safety operation and regulation compliance, it's requested to install a separate DC over-current protector or disconnect device between battery and inverter. It may not be requested to have a disconnect device in some applications, however, it's still requested to have over-current protection installed. The recommended size of protector or disconnect is 150A.



WARNING!

All wiring must be performed by a qualified person.



WARNING!

It's very important for system safety and efficient operation to use appropriate cable for battery connection. To reduce risk of injury, please use the proper recommended cable and terminal size as below. The cable color mentioned below is for typical reference.



WARNING!

Make sure AC power is disconnected before attempting to connect AC power to the unit.

All operations during the electrical connection process, as well as the specifications of cables and components used, must comply with local laws and regulations. The cable color mentioned below is for typical reference.

Recommended battery cable and terminal size:

Gauge	Cable (mm ²)
2 AWG	35

Note: For lead acid battery, the recommended charge current is $0.3C$ ($C \leq$ battery capacity)

Please follow below steps to implement battery connection:

1. Remove insulation sleeve 18mm for positive and negative conductors. Insert the cable into the tubular terminal. Then use terminal crimping tool make the terminal and cable connected tightly.

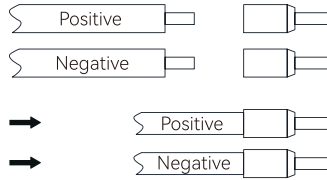

2. Pass the battery cable through the battery installation hole on bottom shell, and tighten the terminal screws. Make sure polarity at both the battery and the inverter is correctly connected and tubular terminals are tightly screwed to the battery terminals.

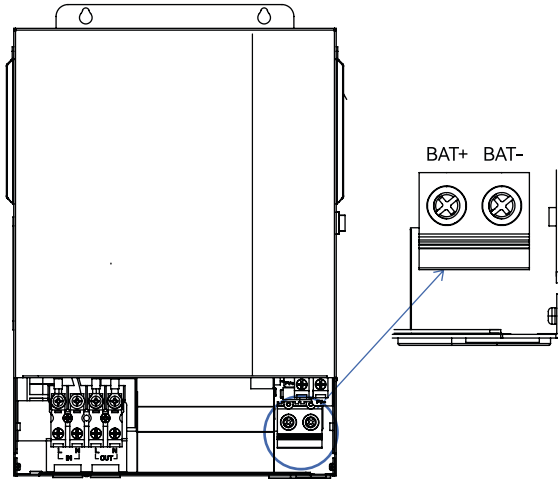

3. Connect all battery packs as units requires. It's suggested to connect at least 200Ah capacity battery.



WARNING! Shock Hazard

Installation must be performed with care due to high battery voltage in series.



CAUTION!

Do not apply anti-oxidant substance on the terminals before terminals are connected tightly.



CAUTION!

Before making the final DC connection or closing DC breaker/disconnector, be sure positive (+) must be connected to positive (+) and negative (-) must be connected to negative (-).

3.6.2 Lithium Battery Connection

Note: Some model of inverter doesn't support BMS and has no BMS interface. Please refer to the inverter you have received for details.

Please follow below steps to implement lithium battery connection:

1. Follow section 3.6.1 to implement the power cable connection.
2. If the inverter support BMS communication, connect RJ45 terminal of battery communication cable to BMS port of inverter. The communication protocol should be RS485. Then insert the other end of RJ45 (battery communication cable) to battery communication port of lithium battery.

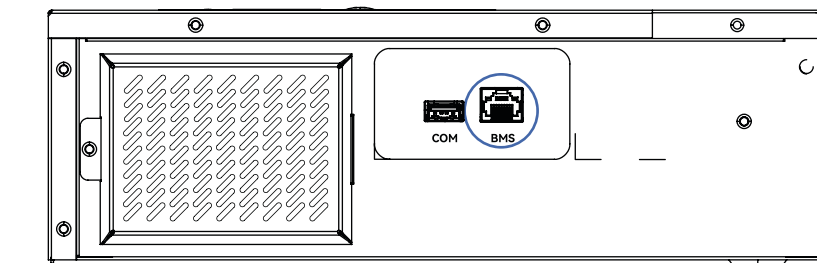

Note: If the battery support BMS communication, please check the compatibility of the protocol first.

BMS communication and setting:

In order to communicate with battery BMS, you should set the battery type to 'Lib' or 'FEL' in Section 4.2.2 Program 17.

Make sure the lithium battery BMS port connects to the inverter is Pin to Pin, the inverter BMS port pin assignment shown as below:

Pin number	BMS port
1	RS485B
2	RS485A
3	-
4	-
5	-
6	-
7	-
8	-

3.7 Final Assembly

After connecting all wiring, please put bottom cover back by screwing two screws mentioned in Section 3.2.

3.8 Smart Communication Stick Connection(Optional)

Note: Some model of inverter doesn't support WIFI monitoring and has no COM interface. Please refer to the inverter interface you have received for details.

The smart communication stick (WIFI) is used to connect to the cloud platform. If the inverter support the WIFI monitoring, please insert the stick into COM port directly, and check the solar APP quick configuration guide.

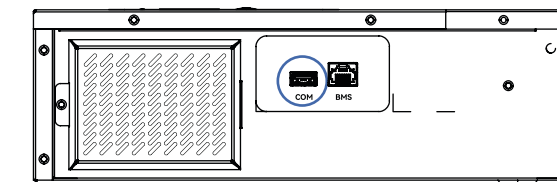

4. Operation

4.1 Power ON/OFF

Once the unit has been properly installed and the batteries are connected well, simply press ON/OFF switch (located on the button of the case) to turn on the unit.

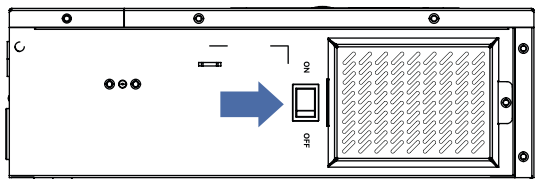

4.2 Operation and Display Panel

The operation and display panel, shown in below chart, is on the front panel of the inverter. It includes four indicators, four function keys and a LCD display, indicating the operating status and input/output power information.

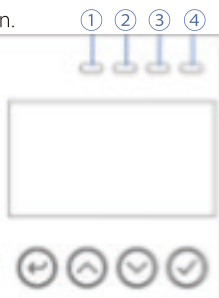

LED Indicator		Messages	
① AC	Status indicator (Green)	Solid On	The mains power is normal and enters the mains power operation.
		Flashing	The mains power is normal, but it has not entered mains power operation.
		Off	The mains power is abnormal.
② Inverter	Invert indicator (Yellow)	Solid On	Output is powered by battery or PV in battery mode.
		Off	Other states.
③ Charging	Charging indicator (Yellow)	Solid On	The battery is in float charging.
		Flashing	The battery is in constant voltage charging.
		Off	Other states.
④ Fault	Fault indicator (Red)	Solid On	Fault occurs in the inverter.
		Flashing	Warning condition occurs in the inverter.
		Off	The inverter is working properly.



ESC



UP



DOWN









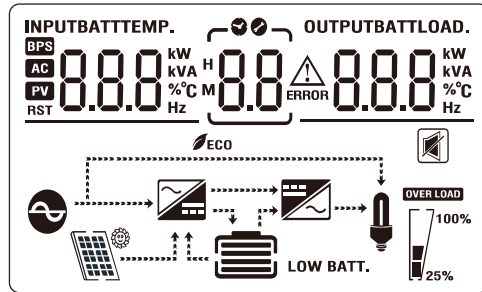

ENTER







Function Buttons

Button	Description
ESC	To exit setting mode
UP	To go to previous selection
DOWN	To go to next selection
ENTER	To confirm the selection in setting mode or enter setting mode





4.2.1 LCD Display Icons



Icon	Description
AC Input Information	
	AC input icon.
	Indicate AC input power, AC input voltage, AC input frequency, AC input current.
PV Input Information	
	PV input icon.
	Indicate PV power, PV voltage, PV current, etc.
Output Information	
	Inverter icon.
	Indicate output voltage, output current, output frequency, inverter temperature.
Load Information	
	Load icon.
	Indicate power of load, power percentage of load.





OVER LOAD	Indicate overload happened.
Battery Information	
	Indicate battery level by 0-24%, 25-49%, 50-74% and 75-100% in battery mode and charging status in line mode.
	Indicate battery voltage, battery percentage, battery current.
Other Information	
	Indicate alarm code or fault code.
	Indicate a fault is happening.
	Indicate the alarm is disabled.
	Indicate power saving mode.

For Lead-acid battery, detailed description of battery icon is related to the settings of the battery low voltage point and battery float charging voltage point. Taking the default settings as example, the specific display is as following:

Battery Cells Voltage	Display
< 11.3V	
11.3V ~ 12.0V	
12.0V ~ 12.7V	
> 12.7V	

4.2.2 LCD Setting

After pressing and holding ENTER button for 2 seconds, the unit will enter setting mode. Press 'UP' or 'DOWN' button to select setting programs. Then press 'ENTER' button to confirm the selection or ESC button to exit.

Program	Description	Setting Option
01	Output voltage	
		230V (default) Adjustable/settable value: 208V, 220V, 230V, 240V
02	Output frequency	
		50Hz(default) Adjustable/settable frequency: 50Hz, 60Hz
03	Output source priority	Grid first (default) 
		(default)Grid is given priority to power the load. If the grid power exit, battery will power the load. Solar only charge the battery in all conditions. If grid and battery power is not sufficient to power loads, inverter will go to standby and charge battery.
		/ 
		Same as GPb(Grid first).
		Battery first 
		Battery is given priority to power the load. If the energy of battery is insufficient, the grid will power the load. Solar only charge the battery in all conditions. If grid and battery power is not sufficient to power loads, inverter will go to standby and charge battery.

03	Output source priority	MKP priority	OPP 03 nLP
		Comprehensive priority When PV exists, the battery takes priority, and when PV does not exist, the grid takes priority.	
04	Output mode	APP: Appliance (default)	nOd 04 APP
		Applied to household appliances	
		UPS	nOd 04 UPS
		Applied to computer and other devices. Typical switching time is 10ms.	
		GEN	nOd 04 GEN
Applied to connect generator by using grid input port			
05	Charger source priority	PNG: PV and Grid (default)	[HP 05 PNG
		PV and Grid are charging at the same time.	
		OPV: Only PV	[HP 05 OPV
		The second is OPV (Only PV). Only PV charge.	
		PV: PV first	[HP 05 PVF
		When both PV and Grid power exist, only PV charging occurs.. When only PV exists, PV charging occurs. When only grid power exists, grid charging occurs.	
06	Grid charging current		FCC 06 30 ^
		30A(default) Available options: 2/10/20/30/40/50A	

07	Maximum charging current	nCC 07 40 ^	
		Set total charging current for solar and grid chargers. The default setting is 40A. Available options: 2/10/20/30/40/50/60/70/80/90/100A	
08	Menu Default	ndF 08 00	
		During setting: Set to ON. If the current page is not on the first page and no operation with 1 minute, the system will return to display the first page. Set to OFF. If the current page is not on the first page and no operation with 1 minute, the system will stay on the current page.	
09	Auto restart when overload occurs	ON(default)	LTS 09 00
10	Auto restart when over temperature occurs	ON(default)	LTS 10 00
11	Main input cut warning	nIP 11 00	
		Enable/Disable Mains or PV loss alarm. The default setting is ON. If the main input detected lost, the buzzer will sound for 3 seconds. When set to OFF, after the main input is lost, the buzzer will not sound.	
12	Energy-saving mode	PUS 12 OFF	
		The default setting is OFF. When set to ON, in battery mode, if the load is lower than 25W, the system will stop output for a period then resume. If the load is still lower than 25W, the system will do the loop stop then resume. If the load is higher than 35W, the system will resume continuous normal output.	
13	Overload transfer to bypass	OLG 13 OFF	
		The default setting is OFF. When set to ON, in the case of PBG priority output, if there is an overload, the system will immediately transfer to bypass mode (utility power output, also known as bypass mode).	



14	Silent mode setting	nUE 14 OFF	
		<p>Enable/disable buzzer sound. The default setting is OFF. When set to ON, in any situation such as alarms or faults, the buzzer will not sound. This setting can be applied to all modes .</p>	
15	Battery return to mains voltage point	bEG 15 11.5V	
		<p>When the battery is set to the AGM (Lead Acid Battery Type) or FLD (Flooded Battery Type) mode, the default setting is 11.5V, and it can be adjusted within a range of [11, 13V].</p>	
		<p>When the battery is set to the LIB (Ternary Lithium Battery Type) mode or FEL(Lithium Iron Battery Type) mode, the default setting is 11.9V, and it can be adjusted within a range of [10, 12.5V].</p>	
<p>When the battery is set to the CUS(Customer Set Type mode), the default setting is 11.7V, and it can be adjusted within a range of [10, 12.5V].</p>			
16	Switching back to battery mode voltage points	bEb 16 13.0V	
		<p>When the battery is set to AGM (Absorbent Glass Mat) or FLD (Flooded) mode,The default setting is 13V. It can be adjusted within a range of [12, 14.5V].</p>	
		<p>When the battery is set to the LIB (Ternary Lithium Battery Type) mode, FEL(Lithium Iron Battery Type) mode or CUS(Customer Set Type mode), the default setting is 13.6V, and it can be adjusted within a range of [11.5, 14.5V].</p>	
17	Battery type	AGM(default)	bAt 17 AGM
		Flooded	bAt 17 FLD
		Lithium (Ternary Lithium Battery)	bAt 17 LIB
		User-Defined	bAt 17 CUS
		Lithium Iron	bAt 17 FEL

18	Battery low voltage point	bAL 18 11.0 ^v
		<p>Battery low voltage alarm setting. It cannot be set when battery type is AGM or FLD. The default setting is 11V.</p>
		<p>When the battery type is set to LIB, FEL, the default setting is 11V. The adjustable range for the voltage is [10.3, 12.5V].</p> <p>When the battery type is set to CUS, the default setting is 11V. The adjustable range for the voltage is [10.5, 13.5V].</p>
19	Battery shutdown voltage point	bAV 19 10.5 ^v
		<p>The battery low voltage shutdown point setting function cannot be adjusted when the battery is defined as AGM or FLD mode. The default setting is 10.5V.</p> <p>When the battery type is set to LIB, FEL or CUS, the battery shutdown point can be modified. The default setting is 10.5V, and the adjustable range is [10, 12V].</p>
20	Constant voltage mode voltage point setting	bCV 20 14.1 ^v
		<p>The battery low voltage shutdown point setting function cannot be adjusted when the battery is defined as AGM or FLD mode. The default setting for AGM is 14.1V, for FLD is 14.5V.</p> <p>When the battery type is set to LIB, FEL or CUS, the default setting is 14.1V, and it can be adjusted within the range of [12, 15V]. It is important to ensure that the constant voltage set point voltage is higher than the float charge set point voltage.</p>
21	Floating charge mode voltage point setting	bFL 21 13.5 ^v
		<p>When the battery is defined as AGM or FLD mode, the voltage set point cannot be configured. The default setting is 13.5V.</p> <p>When the battery type is LIB or FEL, the default setting is 13.8V. It can be set within the range of [12.5, 14.5V].</p> <p>When the battery type is CUS, the default setting is 13.8V. It can be set within the range of [12, 15V].</p> <p>It is important to note that the constant voltage point voltage should always be set higher than the floating charge point voltage.</p>

22	Grid low voltage point setting	LLV 22 154V
		<p>If output mode is APP/GEN, Grid low voltage point can be set within a range of 90V to 154V. The default setting is 154V.</p> <p>If output mode is UPS, Grid low voltage point can be set within a range of 170V to 200V. The default setting is 185V.</p>
23	Grid high voltage point setting	LHV 23 264V
		<p>If output mode is APP/GEN, Grid high voltage point can be set within a range of 264V to 280V. The default setting is 264V.</p> <p>If output mode is UPS, the default setting is 264V and can not be changed.</p>
24	Automatic screen shutdown setting	Atb 24 OFF
		<p>The default value is OFF</p> <p>After turn on the function, the backlight will shutdown after 10 minutes of no button operation.</p>
25	Inverter soft start setting	StE 25 OFF
		<p>The default setting is OFF.</p> <p>If it set to ON, the inverter output gradually increases from 0 to the target voltage value. If OFF, the inverter output directly increases from 0 to the target voltage value.</p> <p>Setting Condition: It can be set in single-machine operation mode.</p>
26	Reset factory setting	Std 26 OFF
		<p>Restore all settings to factory default values.</p> <p>Before the setting, this interface is displayed as OFF. When set to ON, the system will restore to default settings. After the setting is completed, this interface will display OFF again.</p> <p>The setting can be applied immediately in mains and standby modes, but cannot be set in battery mode.</p>

29	Battery Disconnection Alarm	56A 29 OFF
		<p>Enable/Disable battery disconnection alarm.</p> <p>The default setting is OFF. When set to OFF, there will be no battery disconnection, low battery voltage, or battery under voltage alarms when the battery is disconnected.</p>
31	Equalization Voltage Point Setting	E94 31 14.6 V
		<p>The default setting is 14.6V, with a configurable range of [12, 15V].</p>
32	Equalization Charging Time Setting	E9E 32 OFF
		<p>During the equalization stage, the controller will charge the battery as much as possible until the battery voltage rises to the battery equalization voltage. Then, it will adopt constant voltage regulation to maintain the battery voltage. The battery will remain in the equalization stage until the set battery equalization time is reached. The default setting is off, with a configurable range of [off, 5~900], and an increment of 5 minutes for each setting.</p>
33	Equalization Delay Time Setting	E90 33 120
		<p>During the equalization stage, if the battery equalization time expires and the battery voltage has not risen to the battery equalization voltage point, the charging controller will extend the battery equalization time until the battery voltage reaches the battery equalization voltage. When the battery equalization delay setting is completed and the battery voltage is still below the battery equalization voltage, the charging controller will stop equalization and return to the floating stage.</p> <p>The default setting is 120 minutes, with a configurable range of [5, 900], and an increment of 5 minutes for each setting.</p>

34	Equalization Interval Time Setting	E91 34 30
		When the battery connection is detected during the float phase with the equalization mode turned on, the controller will start to enter the equalization phase when the set equalization interval (cell equalization period) is reached. The default setting is 30 days, the settable range is [1,90], and the increment of each setting is 1 day.
35	Enable Equalization Immediately	E97 35 OFF
		The default setting is OFF, the function is not turned on; when it is set to ON, in the float charging stage when the equalization mode is turned on and the battery connection is detected. The equalization charging is activated immediately, and the controller will start to enter the equalization stage.
44	BMS Communication Function	bn5 44 OFF
		Enable/Disable lithium battery communicates with inverter. The default setting is OFF. Choose the corresponding option based on the battery pack type. If a communication abnormality occurs, alarm 56 is generated . Supported protocols: CVT 485 protocol, PYL 485 protocol, GRO 485 protocol, VOL 485 protocol, PAC 485 protocol.
45	BMS ID setting	bn1 45 AtO
		Setting BMS ID number to communicate with. The default setting is auto(AtO). The setting range is [0, 15]. When the item is set to auto(AtO), system will automatically poll the BMS ID from small to large. When system polls for the first ID with a correct response, it locks the ID and only asks the BMS with that ID.

46	Low SOC Shutdown	<div style="text-align: center; border-bottom: 1px solid black; padding-bottom: 5px;">  </div> <p>Set the inverter to shut down when the State of Charge (SOC) of the battery is low.</p> <p>Default setting is 20, with a configurable range of [5, 50]. When the lithium battery SOC reaches the set value in battery mode, the inverter shuts down and generates alarm 68. The alarm 68 is cleared when the SOC returns to the set value + 5%. In standby mode, the inverter can switch to battery mode only when the SOC reaches the set value + 10%. If it does not reach this threshold, alarm 69 is generated. Once the function is enabled, alarm 69 is triggered when the lithium battery SOC reaches the set value + 5%, and it is cleared when it returns to the set value + 10%.</p> <p>It can be set to OFF, in which case the inverter no longer performs shutdown, startup, or alarm operations based on the SOC condition.</p> <p>Once the function is enabled, if a communication abnormality occurs, the inverter no longer operates based on the SOC information and clears the related alarms.</p>
47	High SOC to Battery	<div style="text-align: center; border-bottom: 1px solid black; padding-bottom: 5px;">  </div> <p>Set the SOC value for the inverter to switch to battery mode.</p> <p>Default setting is 90, with a configurable range of [10, 100]. In PBG priority mode, when the lithium battery SOC reaches the set value in normal grid mode, the inverter switches to battery mode. Once enabled, the inverter will only switch to battery mode when the SOC is above the set point and the battery voltage is higher than the voltage point to switch back to battery mode.</p> <p>It can be set to OFF, in which case the inverter no longer switches from grid mode to battery mode based on the SOC condition.</p> <p>Once the function is enabled, if a communication abnormality occurs, the inverter no longer operates based on the SOC information and clears the related alarms.</p>



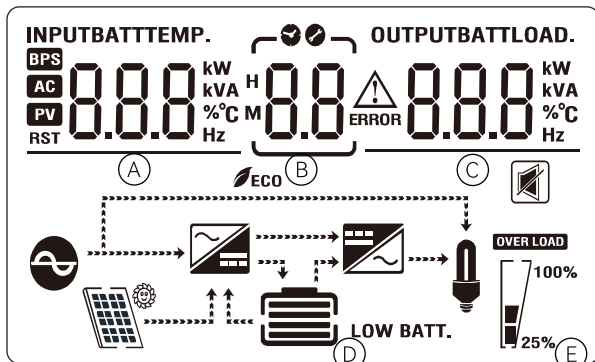

48	Low SOC to Grid	<p style="text-align: center;">560 48 50%</p> <p>Set the SOC value for the inverter to switch to grid mode. The default setting is 50, with a configurable range of [10, 90]. In PBG priority mode, when the lithium battery SOC reaches the set value in battery mode, the inverter switches to grid mode. Once enabled, the inverter will switch to grid mode when the SOC is below the set point or the battery voltage is lower than the voltage point to switch back to grid mode.</p> <p>It can be set to OFF, in which case the inverter no longer switches from battery mode to grid mode based on the SOC condition. Once the function is enabled, if a communication abnormality occurs, the inverter no longer operates based on the SOC information and clears the related alarms.</p> <p>When this setting is higher than the STB point, STB and STG will no longer take effect after the next activation.</p>
61	Max.discharge current	<p style="text-align: center;">ndC 61 OFF</p> <p>The default value is OFF. Available options: Off, 10, 15, 20, 25, 30,35,40,45, 50, 55,60, 65, 70,75, 80, 85, 90, 95, 100, 105, 110.</p> <p>When the battery current exceeds the set value in battery mode, an overload alarm 60 is triggered, and after 5 seconds, an overload fault 14 is reported. If the overload to bypass function is enabled in PBG mode, battery overcurrent will also trigger the overload to bypass logic.</p> <p>It can be set to OFF, and the inverter will no longer trigger overload faults or alarms based on battery current.</p>

4.3 Display Information

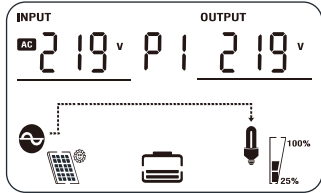
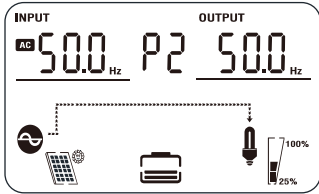
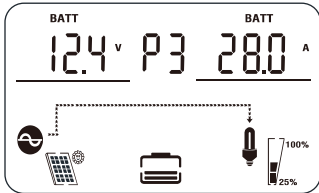
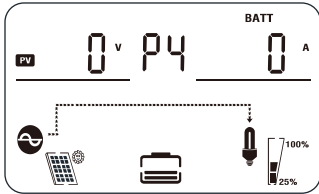
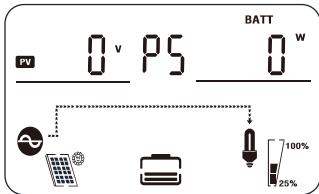
The LCD display information will be switched in turns by pressing 'UP' or 'DOWN' key. The selectable information is switched as below order: voltage, frequency, current, power, firmware version.

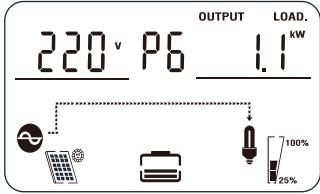
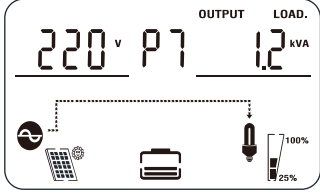
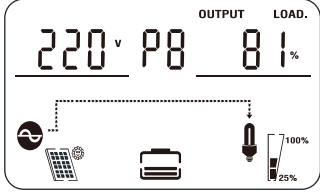

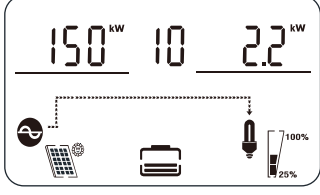
Information	LCD display
<ul style="list-style-type: none"> (A) AC Input voltage (B) Display page number (C) Output voltage (D) Battery capacity (E) Load percentage 	
<ul style="list-style-type: none"> (A) AC Input frequency (B) Display page number (C) Output frequency (D) Battery capacity (E) Load percentage 	
<ul style="list-style-type: none"> (A) Battery voltage (B) Display page number (C) Charge current (D) Battery capacity (E) Load percentage 	
<ul style="list-style-type: none"> (A) PV voltage (B) Display page number (C) PV charging current (D) Battery capacity (E) Load percentage 	
<ul style="list-style-type: none"> (A) PV voltage (B) Display page number (C) PV power (D) Battery capacity (E) Load percentage 	

<ul style="list-style-type: none"> Ⓐ Output voltage Ⓑ Display page number Ⓒ Active power output Ⓓ Battery capacity Ⓔ Load percentage 	
<ul style="list-style-type: none"> Ⓐ Output voltage Ⓑ Display page number Ⓒ Apparent power output Ⓓ Battery capacity Ⓔ Load percentage 	
<ul style="list-style-type: none"> Ⓐ Output voltage Ⓑ Display page number Ⓒ Load percentage Ⓓ Battery capacity Ⓔ Load percentage 	
<p>Display software version</p>	
<ul style="list-style-type: none"> Ⓐ Total power generation Ⓑ Display page number Ⓒ Daily power generation Ⓓ Battery capacity Ⓔ Load percentage 	
<p>Parallel operation status</p>	

After enabling BMS, the following pages are available.

Network status of lithium battery.
When the upper right display shows SIG constant, the battery pack is operating as a single group; When it shows PAR constant, the battery pack is operating in multiple groups in series and parallel; When it flashes PAR, the battery pack is establishing a state of multiple groups in series and parallel

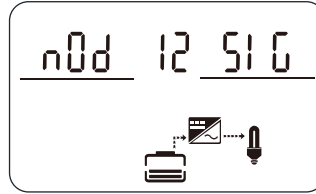

Lithium battery voltage and current information; The upper left displays BMS battery voltage information; The upper right displays BMS battery current information. When BMS communication fails, both the upper left and upper right displays will flash ERR

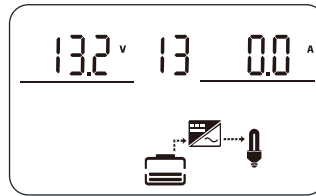

Lithium battery temperature and SOC; The upper left displays BMS temperature information; The upper right displays BMS SOC information. When BMS communication fails, both the upper left and upper right displays will flash ERR

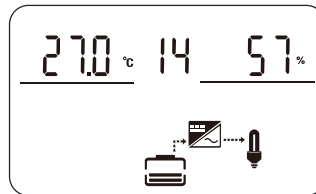

Lithium battery capacity; The upper left displays rated capacity; The upper right displays current capacity. When BMS communication fails, both the upper left and upper right displays will flash ERR



Lithium battery constant voltage point;
 The upper left displays the fixed letter CV; The upper right displays the BMS constant voltage charging point. When BMS communication fails, the upper right display will flash ERR

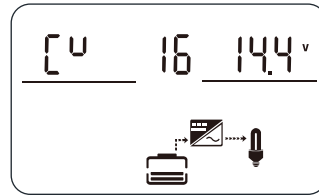

Lithium battery fault alarm information;
 The upper left displays BMS alarm information; The upper right displays BMS fault information. When BMS communication fails, both the upper left and upper right displays will flash ERR

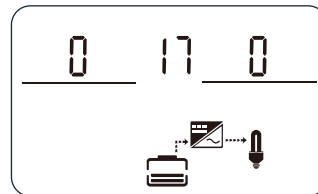

5. Fault Reference Code

Fault display:

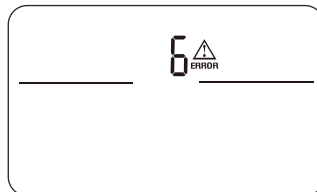

Function description: If alarm occurs, Fault indicator flashes and buzzer sounds every one second for 1 minute, then stop. If fault occurs, the fault indicator is always on, the buzzer sounds 10 seconds then stops. System will try restart automatically. If the machine does not work after six times restart, the machine and LCD display will always be in the fault status. You need to completely power off (off the screen) or wait for 30 minutes to restart the machine. The fault LCD display is shown in the figure above. In fault mode fault icon is bright, in alarm state alarm icon is flashing, and contact the manufacturer to troubleshoot the abnormal situation according to the fault information.

Fault: The inverter enters fault mode, with a constant red LED light and LCD displaying a fault code. The following recoverable faults can be restarted 6 times within 15 minutes. After exceeding 6 times, a fault lock will be triggered, and the fault lock will be released after 15 minutes.

Fault code sheet

Fault code	Meaning	Relevant action	Trigger conditions	Resume conditions
1	Bus soft boost start failed	Turn fault mode	Bus voltage does not reach set value.	Can restore.
2	Bus voltage high	Turn fault mode	The bus voltage is higher than protection point.	Can restore.
3	Bus voltage low	Turn fault mode	Bus voltage is below the under voltage protection point.	Can restore.
4	Battery over current	Turn fault mode	TZ interrupt triggered more than 2 times within 2ms.	Cannot restore.
5	Over temperature	Turn fault mode	The temperature exceeds the protection threshold or fan stuck.	Can restore.
6	Battery high voltage	Turn fault mode	Battery voltage is higher than set value.	Can restore.
7	Bus soft start fault	Turn fault mode	The soft start process has exceeded but the bus voltage has not reached set value.	Can restore.

Fault code	Meaning	Relevant action	Trigger conditions	Resume conditions
8	Bus short circuit	Turn fault mode	Inverter on or PFC on, bus voltage below threshold.	Can restore.
9	Inverter soft start fault	Turn fault mode	After a period of soft start, the inverter still cannot reach the rated output voltage.	Can restore.
10	INV over voltage	Turn fault mode	The inverter voltage is higher than the set value.	Can restore.
11	INV under voltage	Turn fault mode	In battery mode, the inverter voltage is lower than the set value.	Can restore.
12	INV short circuit	Turn fault mode	In battery mode or Standby mode, if the inverter voltage is lower, current is greater than set value.	Can restore.
13	Negative power protection	Turn fault mode	In battery mode, the load power is lower than set value(negative power, such as -1200W).	Can restore.
14	Over load	Turn fault mode	Overload exceeds limit (list in specification).	Can restore.
26	BMS fault	Turn fault mode	Error code in BMS message.	Turn off BMS communication function or BMS fault recovery.
27	MCU fault	Turn fault mode	MCU error.	Cannot restore
29	INV TZ fault	Turn fault mode	In four consecutive half waves, with each half wave triggering more than 10 rapid overcurrent events.	Can restore

6. Alarm Reference Code

Alarm: the inverter does not enter the fault mode, LED red light flashing, LCD displays the Alarm code.

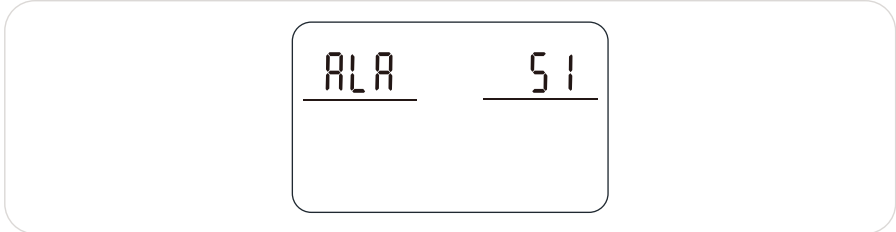

Alarm code sheet

Alarm code	Meaning	Relevant action	Trigger conditions	Resume conditions
50	Battery open	Alarm, battery does not charge.	Battery voltage is below 8V.	Restore after battery voltage >10V.
51	Battery low voltage shutdown	Alarm, battery low voltage shutdown or cannot power on.	Battery voltage is below set point.	Restore after battery voltage recover.
52	Battery low voltage	Alarm	Battery voltage is below set point.	Restore after battery voltage recover.
53	Charger short circuit	Warning, battery does not charge.	The battery voltage is less than 5V and the charging current is greater than 4A.	Cannot restore.
55	Battery over charge	Alarm, battery does not charge.	Battery voltage is higher than the set value.	Restore after battery voltage is < the set value - 0.5V
56	BMS disconnect	Alarm, lock standby mode.	No correct BMS communication response.	Restore after communication recover.

Alarm code	Meaning	Relevant action	Trigger conditions	Resume conditions
58	Fan error	Alarm, if one fan fails and the other fan is running at full speed.	Fan speed is less than the set value.	Restore after fan recover.
60	Overload	Alarm, battery does not charge.	When not in mains mode or the PV is normal and the output priority is not mains priority, the load exceeds 102%.	Restore after load back to normal
68	SOC Under	Alarm, turn standby mode.	Lithium battery SOC is lower than the set value.	Restore after turning off the low SOC shutdown function, or turning off the BMS communication function, or when the SOC returns to the set value + 5%.
69	SOC Low	Alarm, if it is in standby mode, it will remain in standby mode and not power on.	Lithium battery SOC is lower than the set value + 5% (mains mode or battery mode), lower than the set value + 10% (standby mode).	Restore after turning off the low SOC shutdown function, or turning off the BMS communication function, or when the SOC returns to the set value + 10%.
71	Battery short circuit	Alarm	Battery short circuit is detected.	Cannot restore.
72	Battery start up lock	Alarm	Battery voltage do not reach 11.5V/piece(cell).	Can restore.

7. Battery Equalization

Equalization function is added into charge controller. It reverses the buildup of negative chemical effects like stratification, a condition where acid concentration is greater at the bottom of the battery than at the top. Equalization also helps to remove sulfate crystals that might have built up on the plates. If left unchecked, this condition, called sulfation, will reduce the overall capacity of the battery. Therefore, it's recommended to equalize battery periodically.

Note:*Don't activate this mode when using lithium batteries.

- How to Apply Equalization Function

You must enable battery equalization function by set charging time from 'off' to another setting first. Then, you may apply this function in device by either one of following methods:

- 1.Set equalization voltage point on Program 31.
- 2.Set equalization delay time on Program 33.
- 3.Set equalization interval time on Program 34.
- 4.Set immediate equalization mode activation on Program 35.

- When to Equalize

In float stage, when the setting equalization interval (battery equalization cycle) is arrived, or equalization is active immediately, the controller will start to enter Equalize stage.

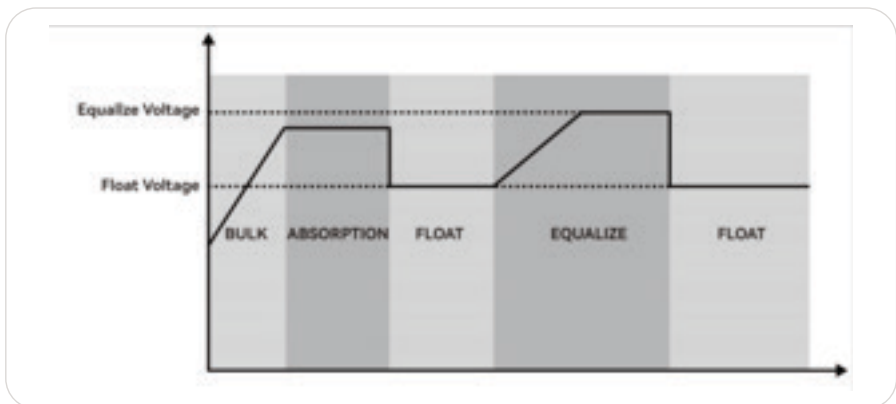

- Equalize charging time and timeout

In Equalize stage, the controller will supply power to charge battery as much as possible until battery voltage raises to battery equalization voltage. Then, constant-voltage regulation is applied to maintain battery voltage at the battery equalization voltage. The battery will remain in the Equalize stage until setting battery equalized time is arrived.

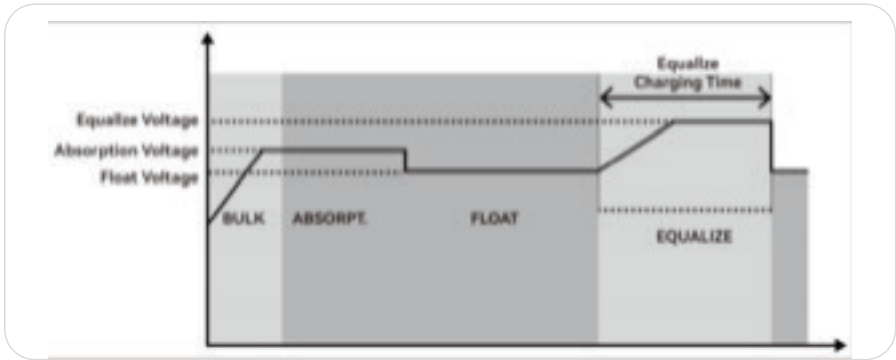

However, in Equalize stage, when battery equalized time is expired and battery voltage doesn't rise to battery equalization voltage point, the charge controller will extend the battery equalized time until battery voltage achieves battery equalization voltage. If battery voltage is still lower than battery equalization voltage when battery equalized timeout setting is over, the charge controller will stop equalization and return to float stage.

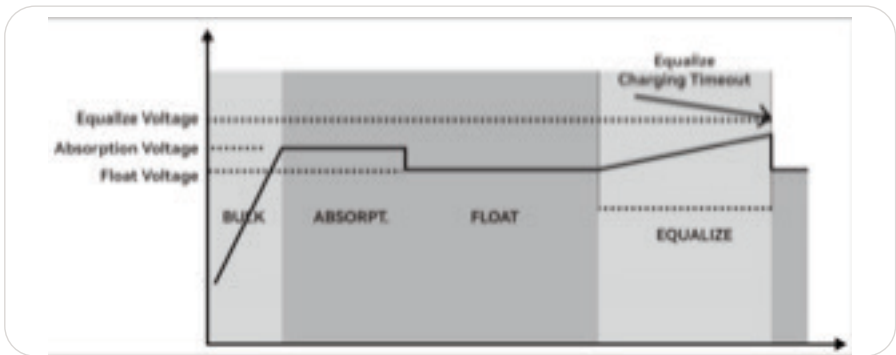

8. Trouble Shooting

Problem	Fault Event	Trigger conditions	What to do
LED screen display fault code 5	Over temperature	Fan lock exceeds 10 seconds.	Please check if the fan is not connected or if there are loose wiring issues. If the fan is not connected for more than 10 seconds, the machine will report fault code 5.
LED screen display fault code 12	Inverter short circuit	In battery mode or standby mode, if the inverter voltage is lower than 80V and the inverter current is greater than 5A, it should respond within 80-100ms.	1.Check if there is a short circuit at the output terminals (such as a screw piercing through the locking terminal causing a LN short circuit). 2.Verify if the inverter voltage and inverter current meet the triggering conditions.
LED screen display fault code 15	Model malfunction	The model number detection does not match any model number.	Check if the control board is assembled incorrectly or if the program is burned incorrectly.
LED screen display fault code 16	No boot program	The third digit of the communication is not 1.	Send command: TIDA1911000000000000
LED screen display fault code 58	Fan malfunction	Any of the fans rotating less than 10 times within 5 seconds.	1.Check if the fan is not connected properly or if there are any loose connections. 2.If the fan is properly connected: a) Check if there is any issue with the fan detection circuit, usually caused by excessive soldering underneath the control board socket. b) Check if the fan itself is damaged.

Problem	Fault Event	Trigger conditions	What to do
Unable to start	Battery	Due to the need for a voltage of $\geq 11.5V/N$ to start the machine in battery mode, common reasons for failure to start include improper calibration or insufficient battery voltage.	<p>1. Check if the battery voltage sampling is functioning properly and if the battery voltage has been calibrated.</p> <p>2. Use a multimeter to measure the voltage at the battery terminals (using a DC power supply or a real battery) to see if it reaches the minimum voltage of 11.5V per cell for startup. Note: It is crucial to configure the battery voltage according to the machine model.</p> <p>3. Check whether BSU configuration in page 46 is accessible. Connecting the wrong battery voltage can cause capacitor explosion.</p>
	Utility power	/	<p>1. Check for any short circuits at the mains terminal (such as a screw piercing through and causing a short circuit between the live and neutral terminals).</p> <p>2. Check if there are any wiring errors, such as mistakenly connecting the mains input to the output terminals.</p>
	PV	/	Check if the PV input voltage is too close to the critical threshold.
PV not charging	/	/	Connecting the wrong battery voltage can result in damage to the auxiliary power supply on the PV side, causing a loss of power and inability to communicate with the main control.

Notes: Updates to the content and version of this manual will not be notified separately.

